





Specialized in casting film
machinery manufacturing



Summarize

1. Introduction

2. Structure

3. History

4. Product

5. Product character

Introduction

Foshan Junjia Machinery Manufacturing Co., Ltd. was established in September 28, 2004, originally as Wan JIA Plastic Co., Ltd. Machinery Division which was established in 1999. Over the years, Junjia focusing on the development and innovation of cast equipments. Junjia successfully developed the first multi-layer cast film line in 1999, becomes one of the first and main enterprises in china that manufactures the cast film line. In recent years, Junjia successfully developed a series of multi-layer of 3~7 layer CPP film production line that reaches the domestic leading level.

JunJia has focused on the research and development of cast film equipment for many years and had a profound understanding of casting film processing technology, accumulated rich experience. The machine model has developed from single-layer to multi-layer, from small size machinery to the multi-layer & multi-functional production line of 3600mm width. The production line covers CPP cast film, CPE elastic film(industrial), PE embossing film, PE ventilated film, EVA film, lithium battery isolating film, PA, EVOH, barrier film etc., and some coating machine such as coating machines and all kinds of composite machines. At present, the technology development and applications of Junjia are in leading position in China.

Structure

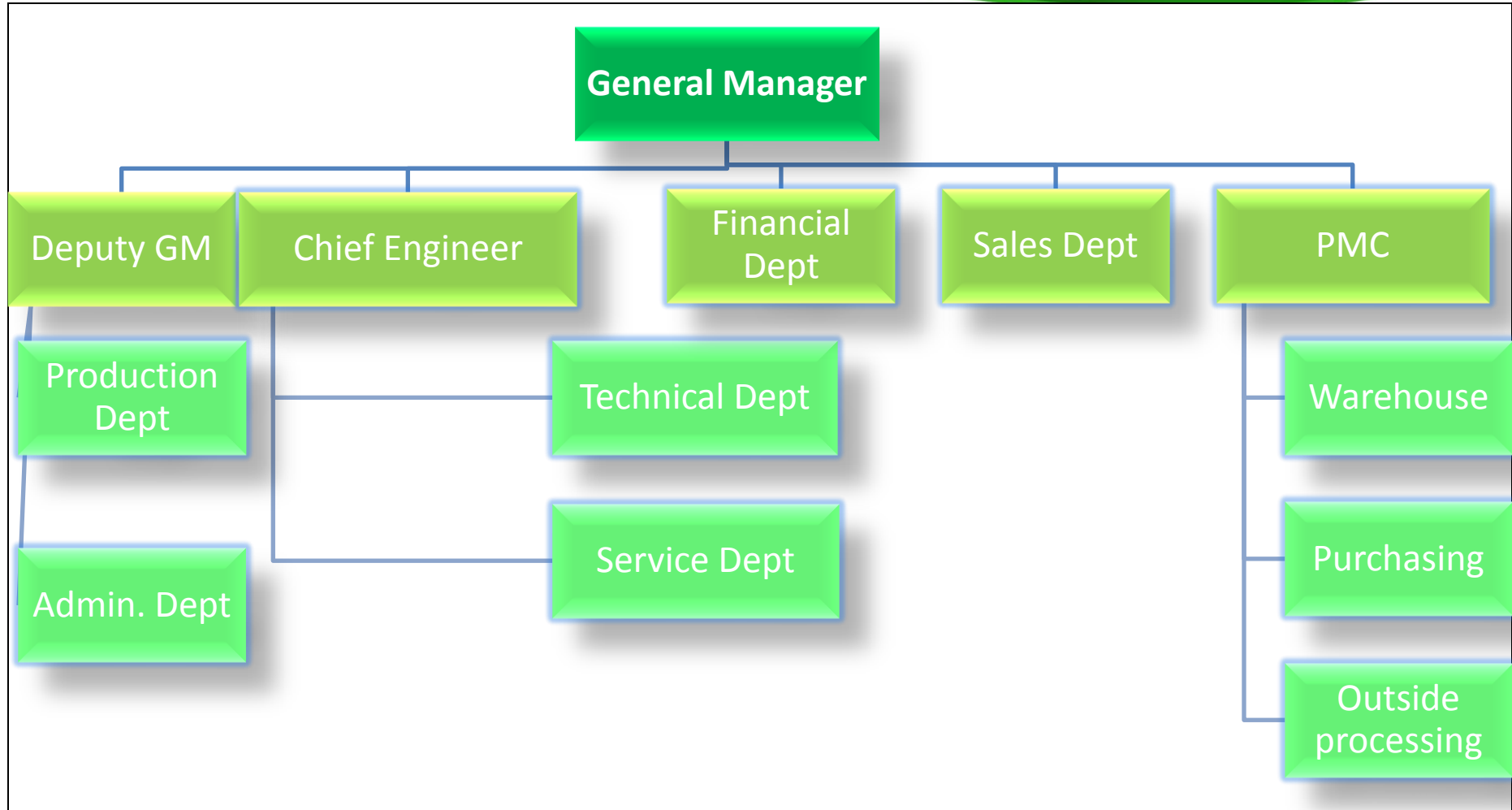



History

- 1999 Established Junjia machinery division
Succeed in developing the first set of multi-layer co-extrusion casting film production line
- 2000 Estalbished JunJia Machinery Manufacturing Co.
- 2001 Successfully made the fist domestic CPP film production line with width 2500mm
- 2002 ISO9001 national quality certification
- 2003 JunJia new factory foundation that coves 53 acres
- 2004 PE ventilated film production line access to Europe market
- 2005-2009 Volume-produce CPP,CPE film production line as well as develop the first two lithium battery isolating film base material production line
- 2010 Produce the high-end CPP cast film production line
- 2011 JunJia & WanJia merged into LIANSU Group

Product

Premier quality, 100% service

Type	Model	Model	Material
Packaging Cast Film	CPP	JJ-CFM CPP cast film production line	PP
		JJ-CFM CPP Multi layer barrier film production line	PP、PA、EVOH、adhesive
	CPE	JJ-CFM CPE cast film production line	
		JJ-CFM CPE Multi layer barrier film production line	PE、PA、EVOH、adhesive
Sanitary Cast film	CPE	JJ-CFM CPE ventilated film production line	PE
		JJ-CFM CPE embossing film production line	PE
		JJ-CFM CPE mette film production line	PE
Functional Cast film		JJ-CFM cast film for lab use	material suitable for cast extrusion
		JJ-CFM lithium battery isolating film production line	PP
		JJ-CFM solar battery encapsulation film production line	EVA
Coating device		Single ,multi layer coated film	PP、PE、EVA
		glue composite machine	PE embossing film
		spray glue composite machine	PE embossing film
		frictioning composite machine	PE embossing film



Features

Premier Quality, 100% Service

- ◆ Stable performance high speed production
- ◆ Low energy consumption
- ◆ Good coiling automation
- ◆ high efficiency scrap recycling

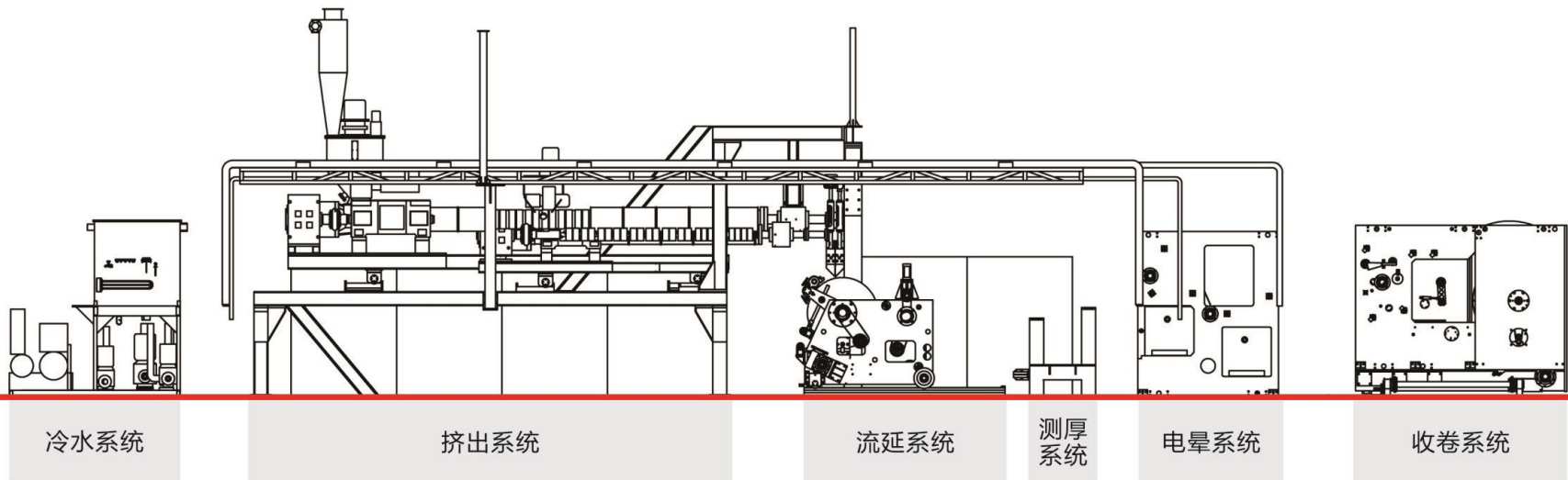



CPP multi-layer co-extrusion

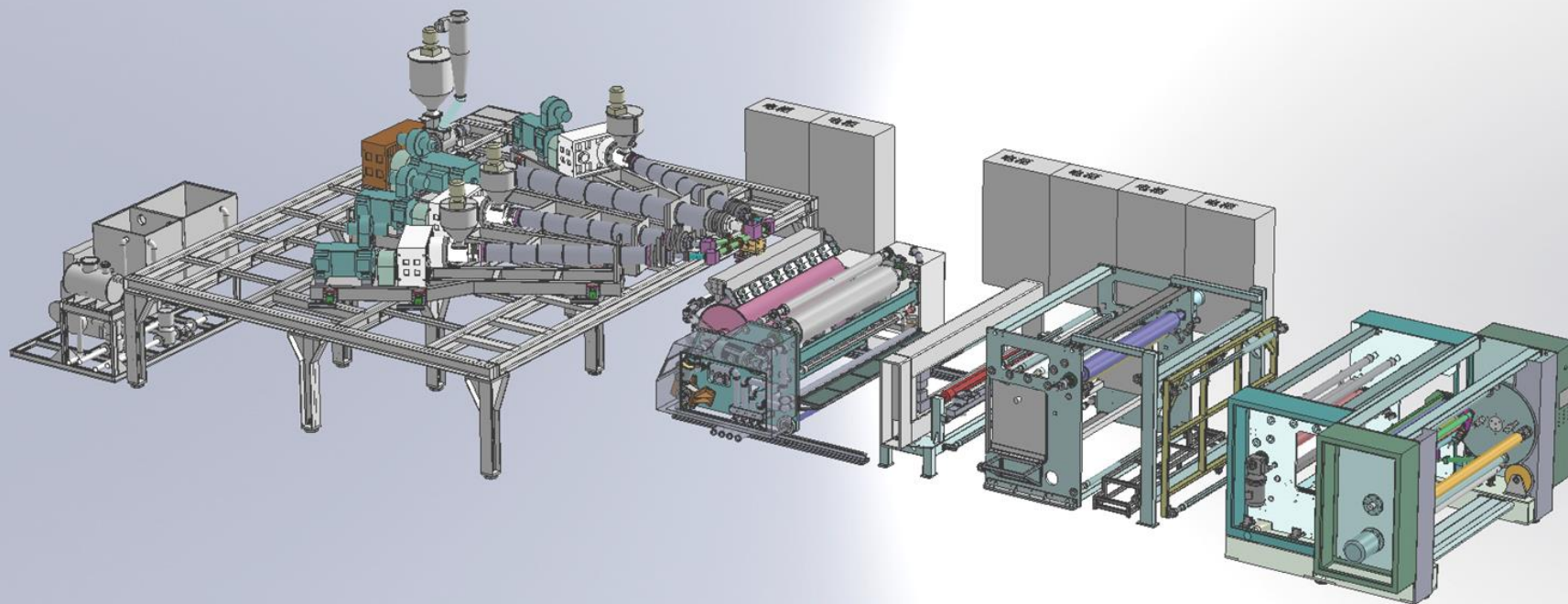

5-7 layers Cast film co-extrusion

CPP casting film production line



Extrusion System

Premier Quality, 100% Service



- Extrusion system adopt two step designed for easy operation and inspection;
- Gravimetric system ensure the stable extrusion.



Flat die: cooperate with Verbruggen(Belgium)



——Belgium VERBRUGGEN oil cooling auto die:

- made of high elasticity alloy steel, flow channel gold plated, double-layer chrom plated, automatic thickening adjust by circulation oil cooling type.
- when all the parameters are stable, the precision tolerance is up to 0.4%, moreover, it operates stably and life expectancy is up to 8~10 years.

Cast roller cooperate with HAHL(Germany)



—pressure loss of water inlet and outlet is only 0.88 Dar caused by advance flow channel design, thin wall design makes the roller temperature control within $\pm 1^{\circ}\text{C}$. Furthermore, the film property and qualification rate are greatly improved because of even temperature and high precision of temperature control, especially it has great adaption to aluminium plated material.



LIANSU



Thickness measuring cooperate with NDC(U.S.)

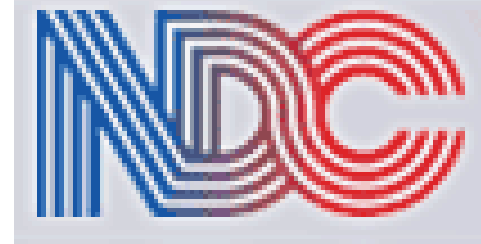

Infrared thickness gauge

——Infrared thickness gauge can take effective control to lateral uniformity and average thickness of the products by combining APC lateral control and linear speed vertical control.

Corona

Premier Quality, 100% Service

- **Danmark VETAPHONE corona**

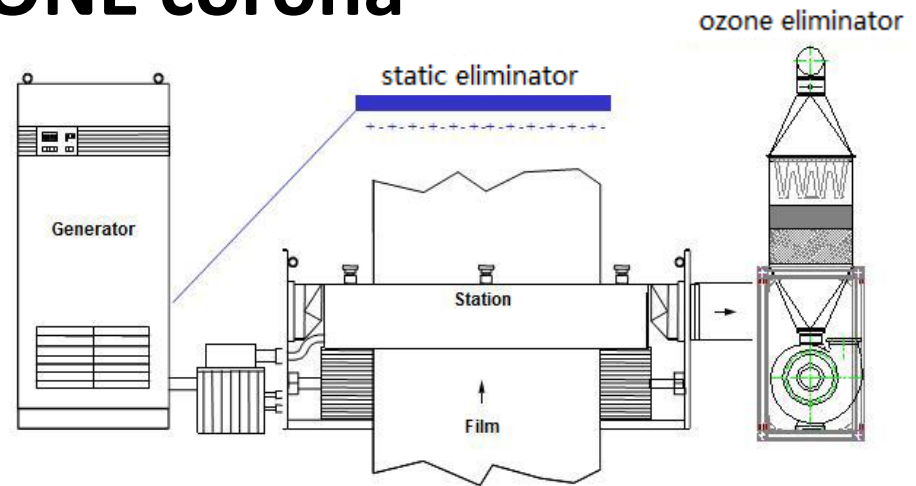

Option:

- Guangzhou Shuman
- Wuxi

Winder

Premier Quality, 100% Service



**NDC FG710 double-
station rotary automatic
winder:**

•**double-station rotary
automatic winder,**

•**effective winding**

diameter $\Phi 800\text{mm}$ 。

Hydraulic unloading

vehicle、Electric shifting

roller machine. max

speed: 200m/min.



LIANSU



俊嘉机械 JUNJIA MACHINE

Control system





LIANSU



circuit connction Premier quality, 100% service

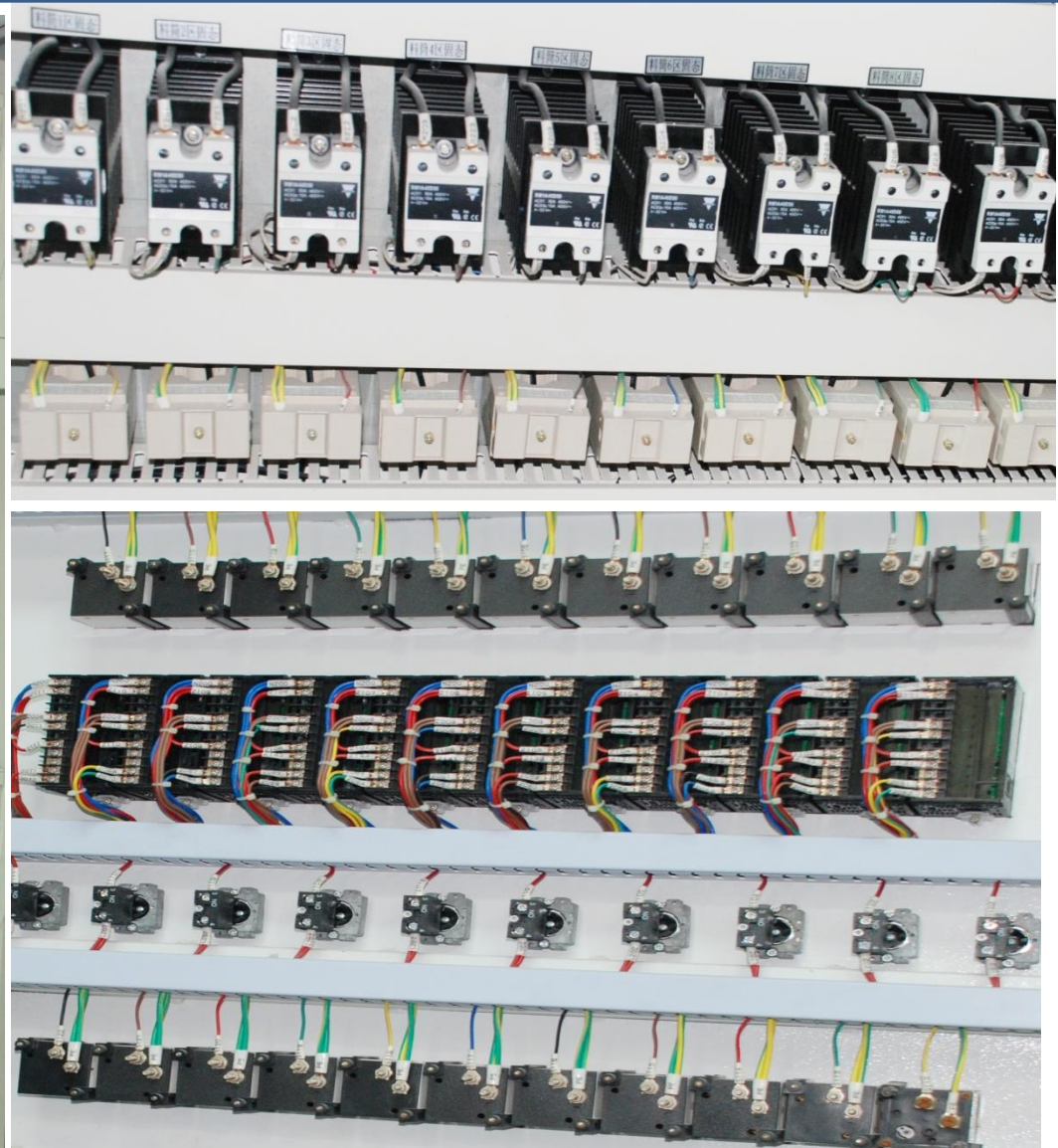



LIANSU



俊嘉机械 JUNJIA MACHINE

circuit connction Premier quality, 100% service



Mono-Layer Structure



3-Layer Structure

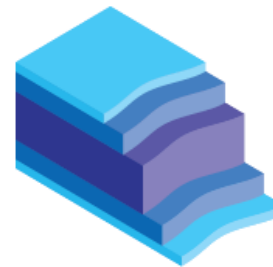

5-Layer Structure



7-Layer Structure





LIANSU



CPE cast film production line

Premier Quality, 100% Service





LIANSU



俊嘉机械
JUNJIA MACHINE

CPE embossing film layout

Premier quality,
100% service

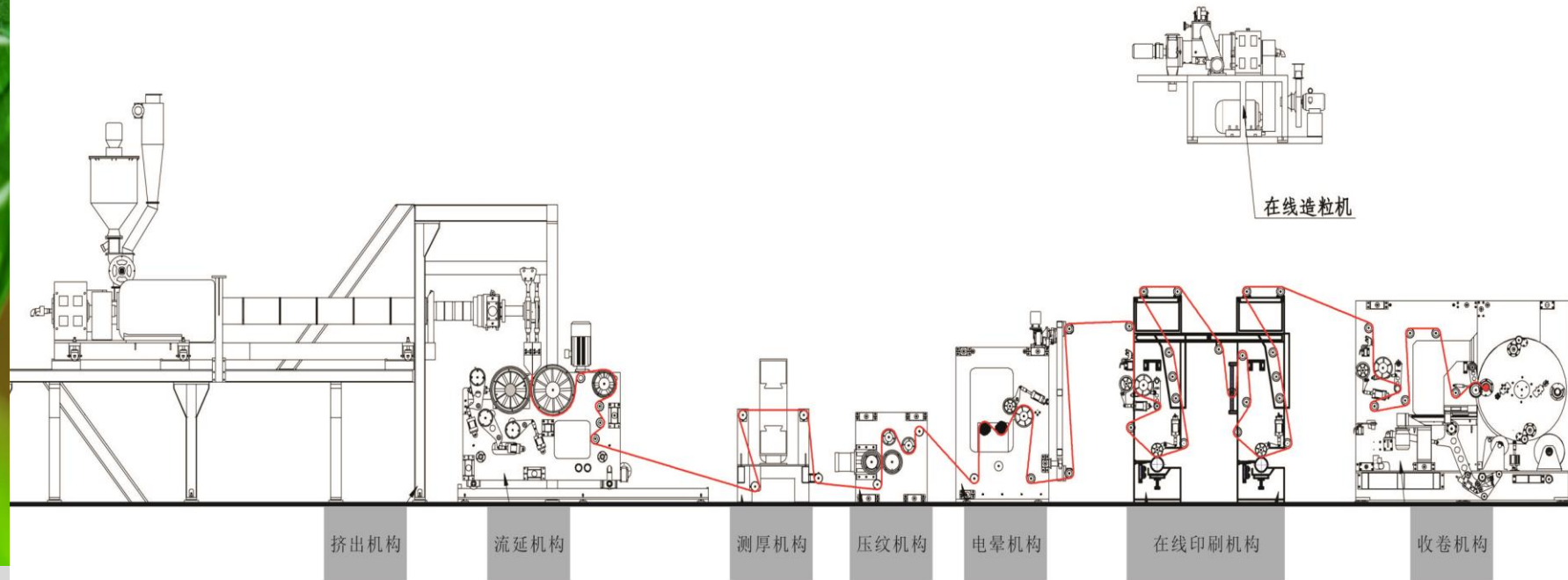

Component view

Premier Quality, 100% Service





LIANSU



Component view

Premier Quality, 100% Service

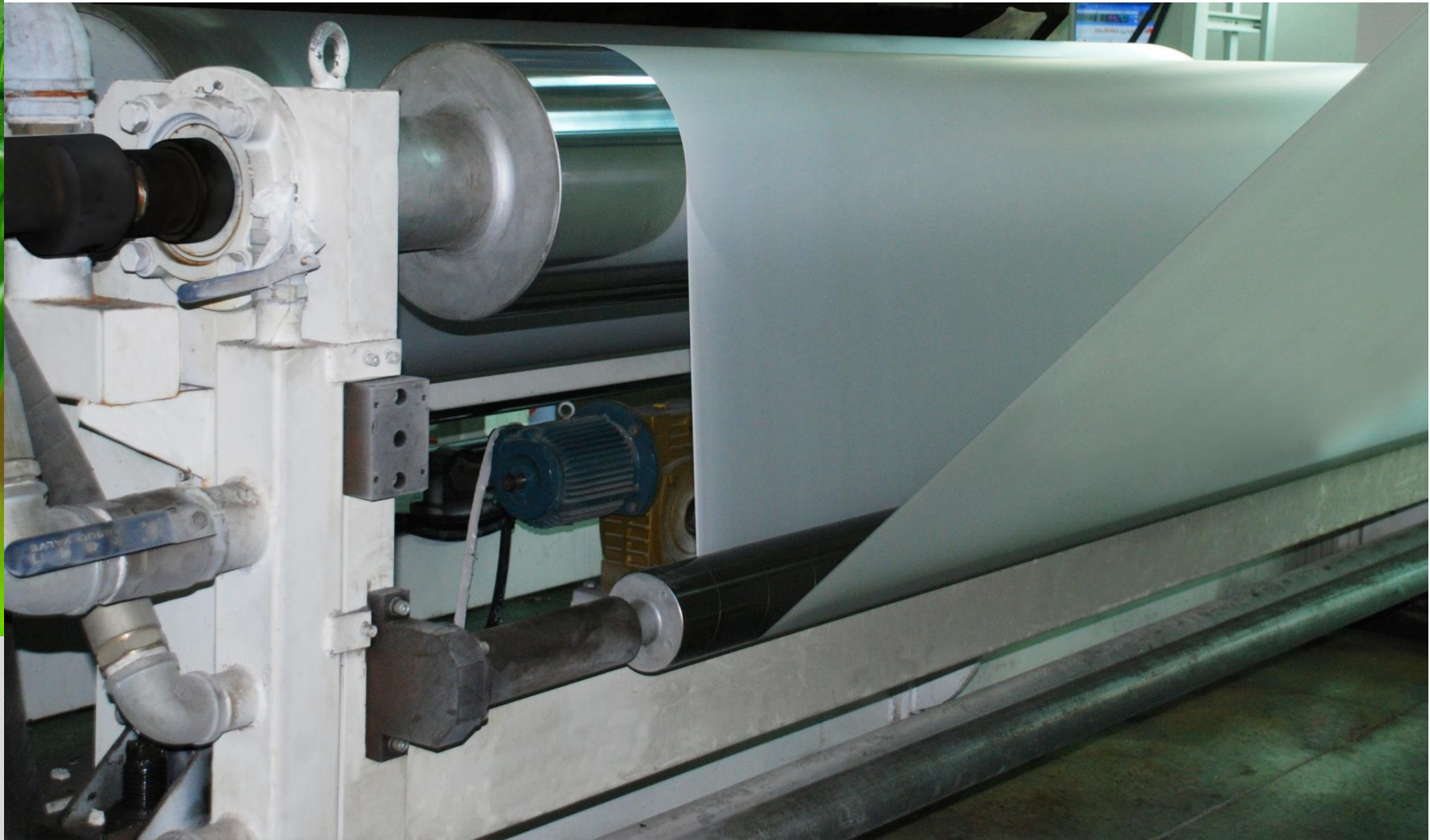



LIANSU

俊嘉机械
JUNJIA MACHINE

Component view

Premier Quality, 100% Service





LIANSU



Premier Quality, 100% Service

CPE equipment part view

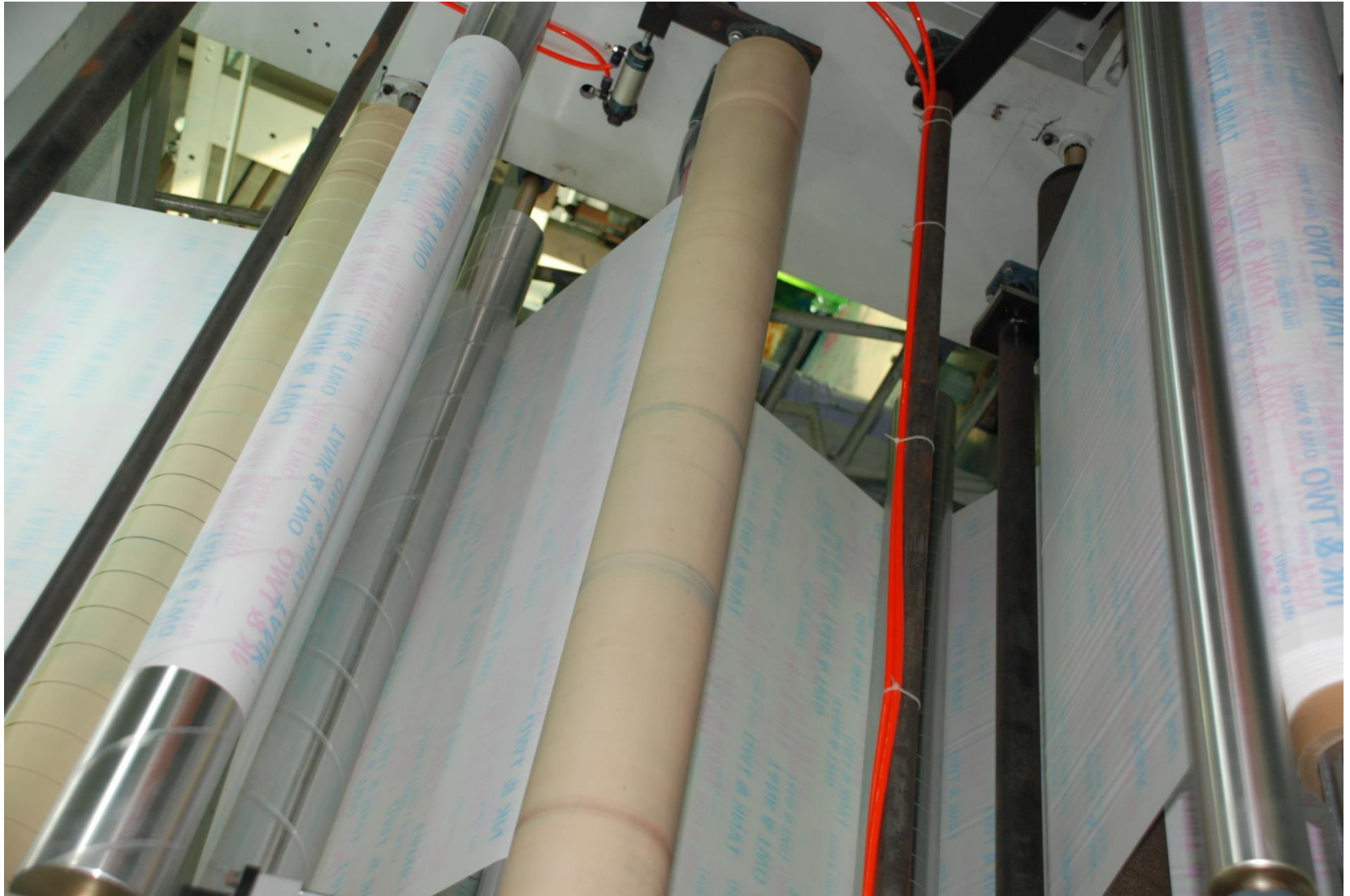

CPE ventilated film production line

Premier Quality, 100% Service

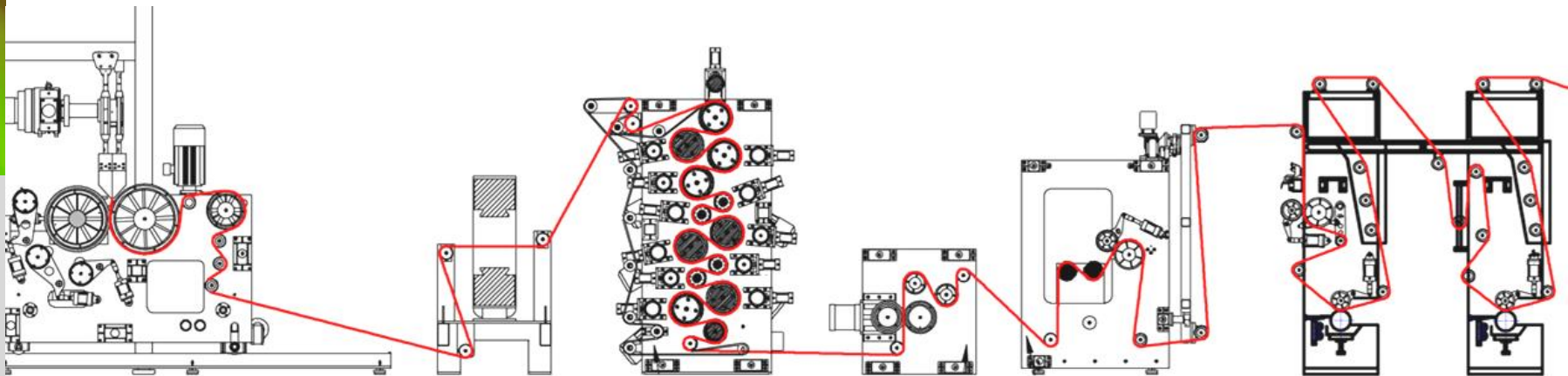
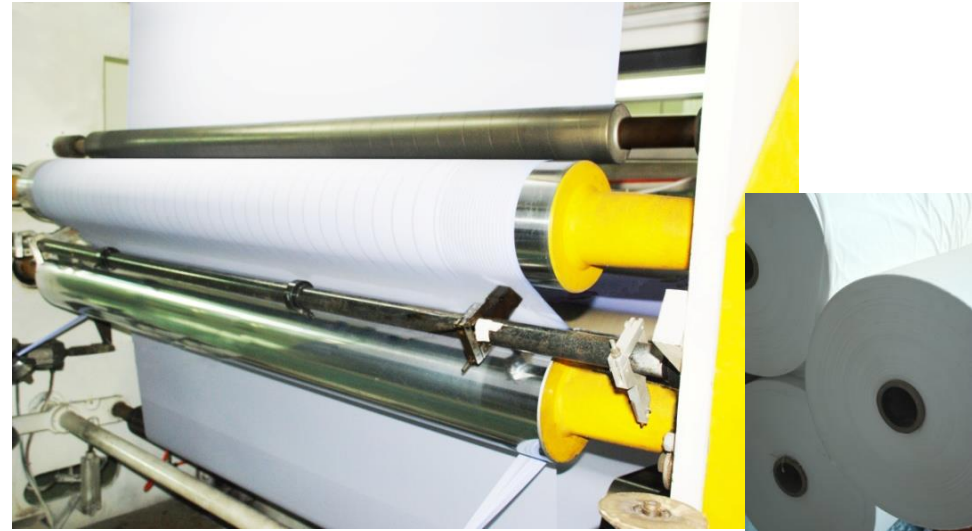
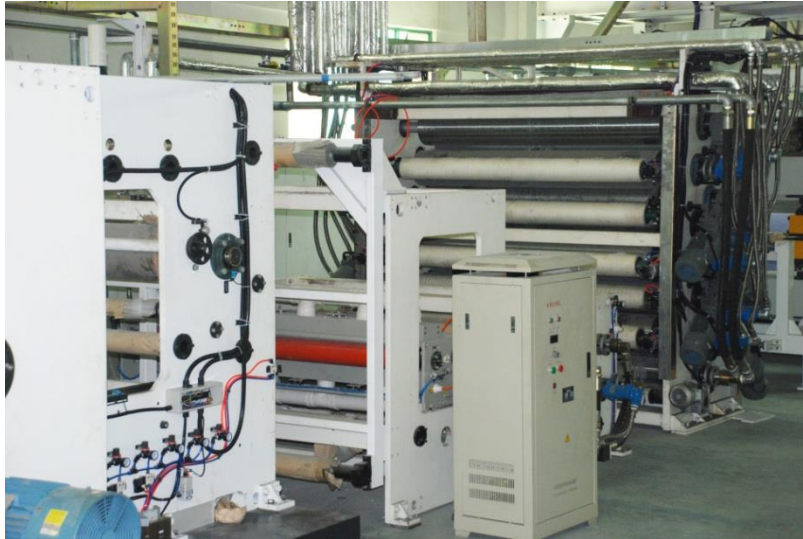



LIANSU

俊嘉机械
JUNJIA MACHINE

Li-ion battery separator production line

Premier Quality, 100% Service





LIANSU



Premier Quality, 100% Service

EVA film production line





LIANSU

俊嘉机械
JUNJIA MACHINE

Isolating film production line

Premier Quality, 100% Service

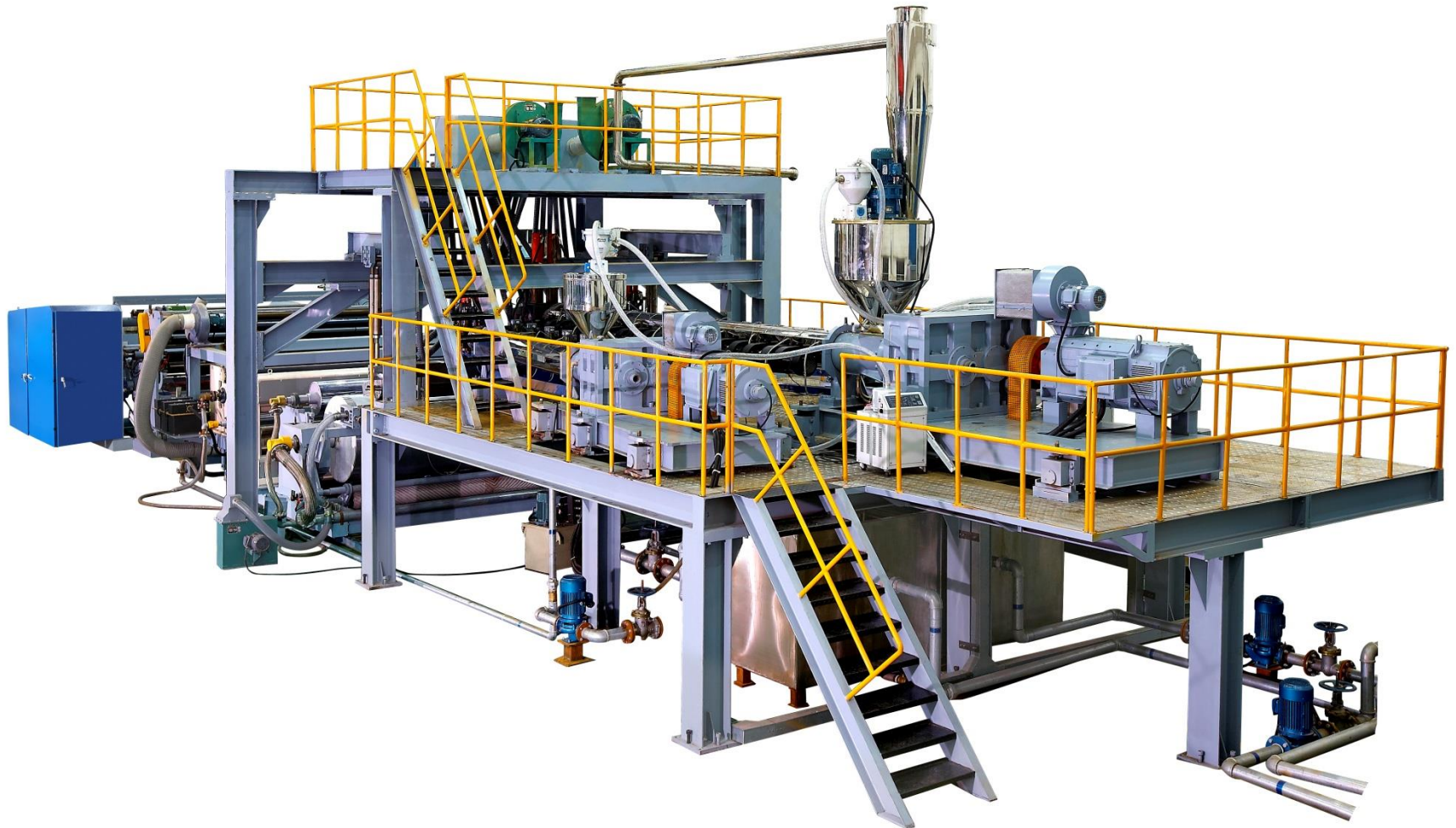



LIANSU



俊嘉机械
JUNJIA MACHINE

Prototype project

Premier Quality, 100% Service



Prototype project:

- 150 lines already sold to worldwide
- China
- East europe
- Asia
- Africa
- Middle east